

RDW-E SELF PRIMING
DEEP WELL PUMP

TECHNICAL DATA

MODEL: RDW100E | RDW150E | RDW200E

AVAILABLE AS PUMP ONLY | WITH PRESSURE CONTROLLER | WITH PRESSURE TANK, SWITCH & GAUGE

CHARACTERISTICS & PERFORMANCE DATA

TYPE	Nominal Power (P2)		Input Power (P1)	Input Current (A)	Capacitor
	W	HP			
Single Phase	W	HP	W	240V	[μF]
RDW100E	740	1	930	4.1	16
RDW150E	1100	1.5	1800	7.9	30
RDW200E	1470	2	2340	10.3	36

	EJECTOR TYPE	SUCTION DEPTH (M)	L/MIN	HEAD (M)										
				3	6	10	15	20	25	30	35	50	60	
RDW100E	P20	15	HEAD (M)	40	38	36	31	28	24	20				
		20		38	36	32	26	21	17					
	P30	25				40	32	15						
		30				38	30							
		35				33	20							
RDW150E	P20	15								37	32	25	17	
		20							40	30	27	20		
		25							36	27	25			
	P30	35				52	41	20						
		40				43	30							
		50		49	40	15								
RDW200E	P20	15									43	35		
		20							43	39	28	23		
		25							40	31	24	17		
	P30	35				50	35	15						
		40				49	42	19						
		50				47	30							

DIMENSIONS & WEIGHT

RDW100E

DEEP WELL PUMP RDW

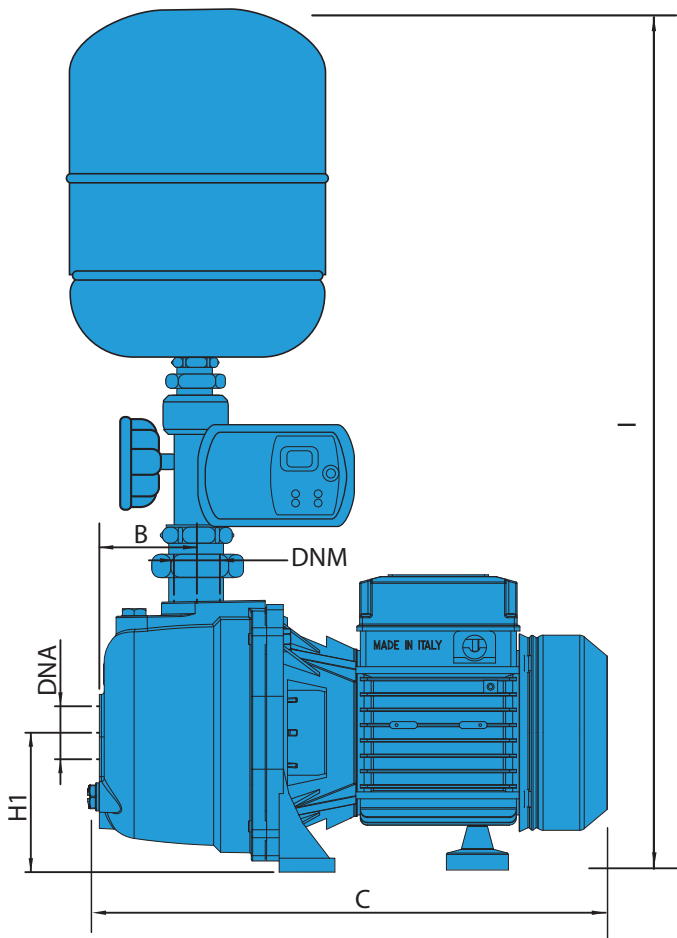

RDW-E WITH PRESSURE SWITCH

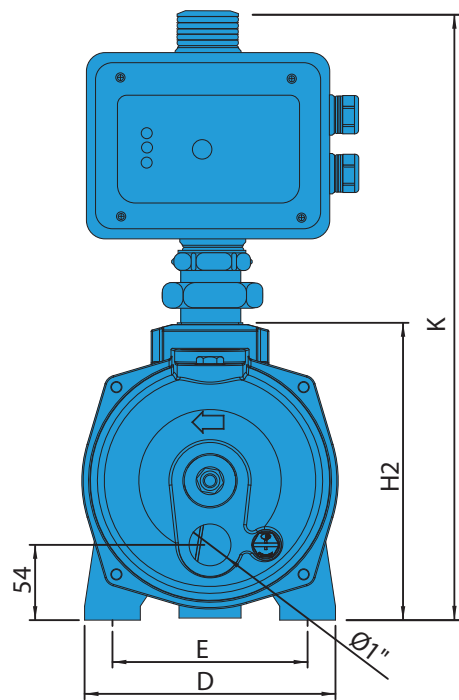

RDW-E WITH PRESSURE CONTROLLER

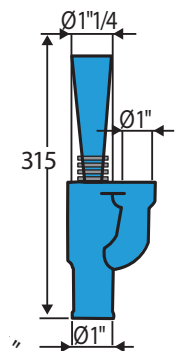

MODEL	DIMENSIONS (MM)													PACKING (PUMP ONLY) (MM)			WEIGHT (KG)
	A	B	C	D	E	F	G	H1	H2	DNA	DNM	I	K	L	W	H	
RDW100E	-	85	370	180	140	-	-	100	188	1 1/4"	1"	388	628	250	450	190	14.3

DIMENSIONS & WEIGHT

RDW150E | RDW200E

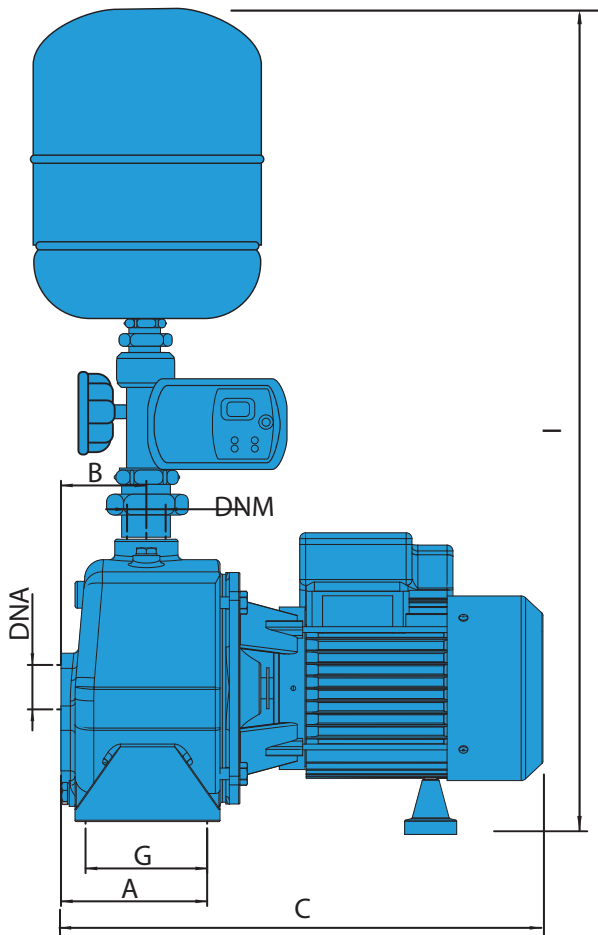

RDW-E WITH PRESSURE SWITCH

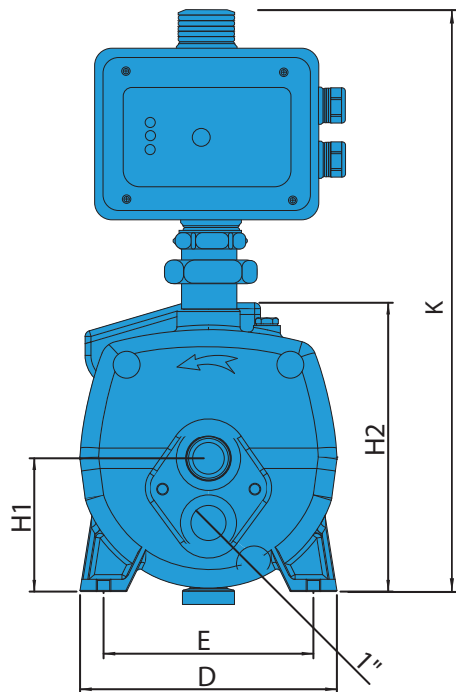

RDW-E WITH PRESSURE CONTROLLER

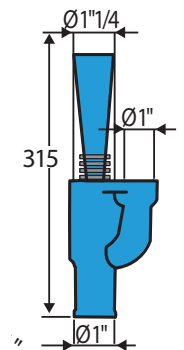

DEEP WELL PUMP RDW

MODEL	DIMENSIONS (MM)													PACKING (PUMP ONLY) (MM)			WEIGHT (KG)
	A	B	C	D	E	F	G	H1	H2	DNA	DNM	I	K	L	W	H	
RDW150E	125	74	415	226	174	-	104	120	248	1 1/4"	1"	688	448	350	430	240	27.3
RDW200E	125	74	415	226	174	-	104	120	248	1 1/4"	1"	688	448	350	430	240	28.9